

8. N. N. Aronova and A. V. Shurchkov, in: *Physical Processes in Mining* [in Russian], Leningrad (1985), pp. 26-32.
9. V. A. Mukhin and N. N. Smirnova, *Prikl. Mekh. Tekh. Fiz.*, No. 4, 110-115 (1981).
10. R. S. Nustrov and B. N. Saifulaev, *Inzh.-fiz. Zh.*, 54, No. 5, 779-786 (1988).
11. Yu. A. Buevich and E. B. Pershikov, *Inzh.-fiz. Zh.*, 38, No. 1, 29-37 (1980).
12. Yu. A. Buevich, *Inzh.-fiz. Zh.*, 54, No. 5, 770-779 (1988).

APPROXIMATE APPROACH TO SOLUTION OF THREE-DIMENSIONAL HEAT CONDUCTION PROBLEMS

V. V. Gorskii, A. M. Sigitova, and M. N. Televnyi

UDC 536.2

An approximate approach is presented for the solution of a three-dimensional heat conduction problem for one type of heat-protective coating frequently encountered in practice. The method proposed, based on the reduction of the initial three-dimensional problem to a set of two problems of less dimensionality, makes it possible, with satisfactory precision, to shorten substantially the computer time spent in determining thermal conditions of elements of a given design.

Aircraft bodies are, at the present time, in the majority of cases, thin-walled supporting metallic shells coated on the outside and (or) inside with a many-layered heat insulation. Large flight speeds at nonzero angles of attack give rise to high thermal flow densities and a resulting nonuniformity in the distribution of these flows over the structural surface. Flow-on and flow-off directions, and different nodes of pressure and rarefaction at locations shaded by aerodynamic elements, give rise to zones of minimum and peak loads on an object. To correctly estimate the thermal state of an aircraft, it is necessary under these conditions to consider the heat conduction equation in three dimensions. A rigorous solution of a similar problem by traditional numerical methods becomes in some cases (in carrying-out algorithms in a "real time scale" or in handling large-scale computational systems) impractical due to the resulting high expenditure of machine time. In the present paper we present one of the possible approaches to solving a nonstationary three-dimensional heat conduction problem, an approach which makes it possible, with satisfactory precision, to obtain results with substantially less computational time spent in determining thermal conditions of elements of a structural object.

A basic feature of the engineering method presented here is the fact that three-dimensional calculation of heat conduction of the shell is reduced to a set of two problems: two-dimensional initial heating of the supporting framework, with neglect of temperature drop over its thickness, and a one-dimensional initial heating of the thermal insulation in a direction perpendicular to the surface of the metallic layer. Here a direct calculation of the temperature field over the structure is carried out while solving the indicated one-dimensional problem using values of a source function in place of the metallic layer arrangement. The source function is calculated within the scope of the two-dimensional heat conduction problem and is connected with thermal overcurrents in longitudinal and transverse directions. In particular, the source function for the case involving calculation of an element of an axially-symmetric shell has the following form:

$$q^S = \delta \left(\frac{Q_{i-1} - Q_i}{l} - \frac{Q_{i-1} + Q_i}{2r} \operatorname{tg} \theta + \frac{Q_{j-1} - Q_j}{rd\varphi} \right).$$

The physical justification for use of such an approximate approach is based on a qualitative difference in the coefficients of thermal conductivity of elements of the structure of the type considered and also on the relatively small thicknesses of the metallic layer.

Translated from *Inzherneno-fizicheskii Zhurnal*, Vol. 61, No. 2, pp. 319-322, August, 1991. Original article submitted May 10, 1990.

Approval of the formulated method for solving three-dimensional heat conduction problems was carried out with calculation of the initial heating of a shell consisting of a steel cylindrical tube of length 0.4 m with outside radius 0.2 m and 2 mm thick. The shell was coated from within with a 10 mm layer of heat insulating material. In the axial direction the structure was divided into five sections with coordinates 0.044; 0.132; 0.264; 0.352; and 0.4 m. Extent of the elements in the meridional direction was 36°. The thickness of the heat insulating layer was divided into five zones, each 2 mm thick. In turn, the zone closest to the heated surface was divided uniformly into ten subzones. Thermophysical properties of the materials used in the calculations: coefficient of thermal conductivity of the supporting metallic layer, $\lambda_{\text{met}} = 100 \text{ W/m}\cdot\text{K}$; coefficient of thermal conductivity of the heat insulation coating material, $\lambda_{\text{hic}} = 0.007 \text{ W/m}\cdot\text{K}$; the corresponding volumetric heat capacities were $C_{V,\text{met}} = 2 \cdot 10^6 \text{ J/m}^3 \cdot \text{K}$ and $C_{V,\text{hic}} = 0.5 \cdot 10^6 \text{ J/m}^3 \cdot \text{K}$; these thermophysical properties are close to the real characteristics of these types of metallic structures and heat insulators widely used in practice.

To guarantee sensible nonuniformity of the temperature field on the surface of the shell and, consequently, to satisfy conditions for estimating effectiveness of the approximate method, thermal loading parameters were chosen a fortiori anomalously. External enthalpy of damping was taken equal to 3 MJ/kg and, in order to avoid "thermal shock," it appears linearly at this level in the course of the first 10 sec of heating. The interior surface of the body was subjected to air blown over with retardation enthalpy of 1.4 MJ/kg and with heat transfer coefficient equal to 0.0012 kg/m²·sec. The heat transfer coefficient on the outer surface of the structure was taken in the form of a linear function

$$\alpha_{i,j}^w = A \left(1 - \frac{0,9}{X_{N_x}} (X_i - X_1) \right),$$

where

$$A = 0,15 \left(1 - \frac{j-1}{N_\varphi} \right).$$

Shell with Heat Insulated Ends. Total heating time amounted to 300 sec. Integration step over the time coordinate was taken equal to 0.25 sec.

In determining temperature conditions for the structure described above elementary thermal balances were compiled at its computational nodes. Here we used the Fourier equation in cylindrical coordinates, presented in finite-difference form. Thermal balances were established with respect to a difference of temperatures according to an explicit scheme with boundary conditions of the third kind on the outer and inner surfaces of structural batches.

Figures 1 and 2 display graphs of comparison of temperature conditions of the supporting metallic layer for the structure considered, different approaches having been used. The continuous curves show the results obtained in solving a rigorous three-dimensional heat conduction problem; the dashed curves relate to calculations obtained in accordance with the approximate method presented in this paper; and the dash-dot curves show the results of calculations obtained within the scope of the one-dimensional approach.

The difference in the temperature conditions of the structure, calculated using the first and third of the methods cited, characterizes the role of the three-dimensional heat conduction process in the given case. As is evident from the data presented, this difference attains a value of 370°C when the structure is heated to 1160°C, i.e., the influence of conductive thermal overcurrents in the longitudinal and transverse directions is very significant in the formation of the thermal state of the body. At the same time, use of the present approximate approach makes it possible to "liquidate" at least 90% of the indicated error, which testifies to the possibility of its use for thermal calculations for a structure of the type indicated. In this connection, it should be noted that the accuracy of the present approach to calculation of temperature conditions of structures of the type considered depends on the relationship of thermophysical properties of the metallic layer materials and the insulation material. In particular, as the values of the thermal conductivity coefficients of these materials tend to differ less from one another, the accuracy of the calculations decreases.

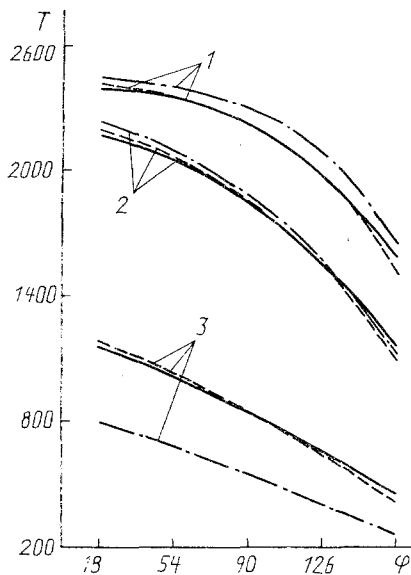

Fig. 1

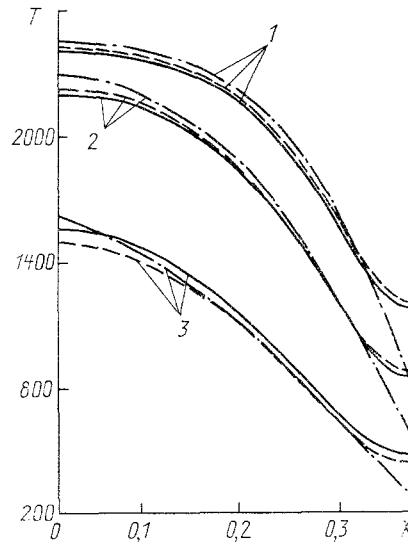

Fig. 2

Fig. 1. Comparison of temperature profiles at axial sections of the body for different calculational schemes at time $t = 100$ sec. Values of X_i , m, for curves 1, 2, 3 are 0; 0.2; 0.4; T is in $^{\circ}\text{C}$; φ is in degrees.

Fig. 2. Comparison of temperature profiles along a generator of the body for different calculational schemes at time $t = 100$ sec. Values of φ_j , for curves 1, 2, 3 are 18; 90; 162 $^{\circ}$.

Machine time on the BESM-6 Computer for a rigorous three-dimensional version of the calculations amounted to 12 h; time spent on the approximate approach was 1 h and 40 min, approximately a 7-fold decrease in computing time. It is necessary to take into account here that this economy can become even more substantial if the integration time step is taken equal, not to 0.25 sec (its maximum value for a rigorous solution of the problem), but to 1 sec (time limitation for use of the approximate method).

NOTATION

Q^S , source function, W/m^2 ; Q_{i-1} , Q_i , conductive thermal flows: leading to the initial longitudinal section of the element's metallic layer and away from the end section, W/m^2 ; δ , metallic layer thickness, m; l , longitudinal dimension of projection of computing element on axis of symmetry, m; r , mean radius of computing element, m; θ , angle of inclination of generator of shell to axis of symmetry, deg; $d\varphi$, meridional angular size of computing element, radians; $\alpha_{i,j}$, heat transfer coefficient at i -th section of axial direction on j -th generator of body, $\text{kg}/(\text{m}^2 \cdot \text{sec})$; X_i , linear coordinate of i -th computing section in axial direction, m; NX , number of sections in axial direction; $N\varphi$, number of generators of body on which thermal calculations are carried out; i , j , number of section in axial direction and number of generator; φ_j , value of meridional angle of j -th generator; λ_{met} , $C_{V,\text{met}}$, coefficients of thermal conductivity ($\text{W}/(\text{m} \cdot \text{K})$) and volume heat capacity ($\text{J}/(\text{m}^3 \cdot \text{K})$) of supporting metallic layer material; λ_{hic} , $C_{V,\text{hic}}$, coefficients of thermal conductivity ($\text{W}/(\text{m} \cdot \text{K})$) and volume heat capacity ($\text{J}/(\text{m}^3 \cdot \text{K})$) of heat insulation coating material.